

Sky Tunnel

XL²

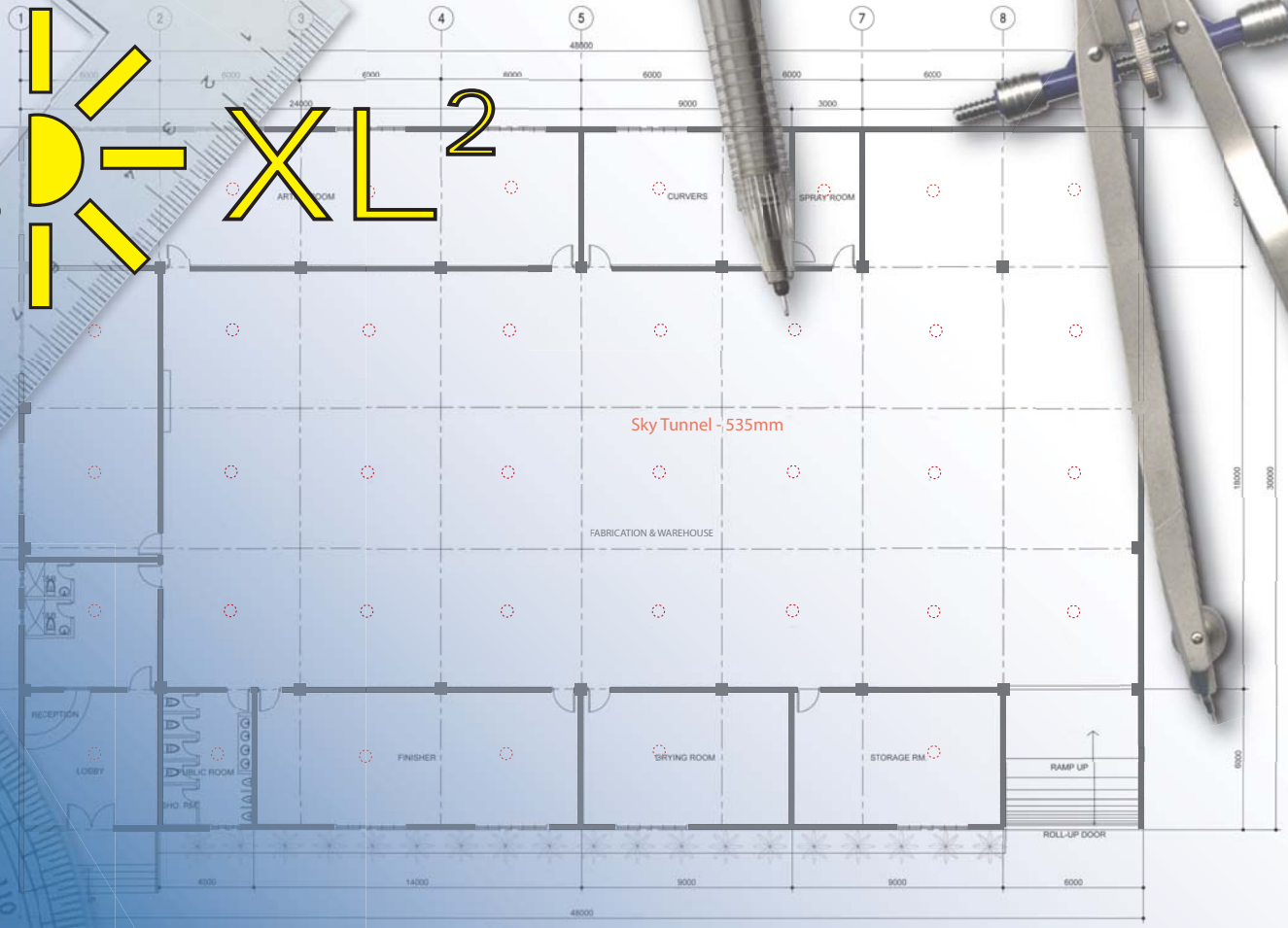

Commercial and Industrial Daylighting Systems



SkyTunnel XL²

Introducing clear and comfortable daylight has never been easier. Natural daylight ensures that the people working or living in the indoor environment are happier and healthier.

By making an environmental choice and utilising this renewable energy, you will be helping to reduce the consumption of our environments precious resources, and saving money at the same time.

Available in 3 sizes, 343mm, 457mm & 535mm diameters, there is a size to suit any application. Sky Tunnel™ sizes offer more actual light area than a typical 350mm, 450mm or 550mm tubular skylight available on the market. A little extra light, can go a long way!

SG Eco Industries is the manufacturer of the Sky Tunnel™ and do not compromise on quality, design, materials or structural integrity. Adhering strictly to the structural requirements set out by both the British Board of Agrément and Australian Standards. Raw materials are sourced from all over the globe to ensure only the best quality materials are incorporated into the Sky Tunnel™ product.

Tested by time, Sky Tunnel™ is designed to withstand the rigors of use in commercial buildings, and for this reason construction companies have been using them for over 20 years. For commercial buildings, the energy savings can be quite easily calculated, and the return on your investment is often under 2 years, when including: Savings in energy costs, increased human productivity and improvement in quality control leading to reduced re-works.

Sky Tunnel™ has a 7 Year Manufacturers Warranty!



APPLICATIONS

Sky Tunnel™ is suitable for almost any Industrial or Commercial Application where you see electric lights being operated during daylight hours. This includes applications such as Warehouses, Factories, Offices, Reception Areas, Gymnasiums, Retail Shops etc.



Sky Tunnel XL² COMPONENT SPECIFICATIONS

Sky Tunnel™ with Rigid98

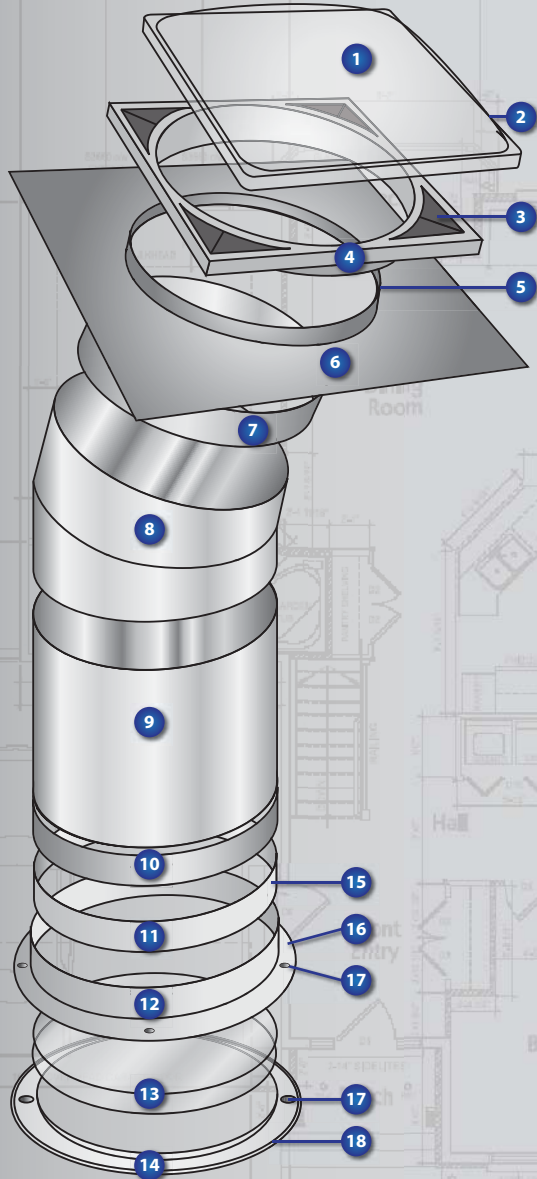

- 1) **DOMES** – U.V. Stabilized Grade 1 Acrylic (Altuglas – HFI7) or Specialised UV Grade Polycarbonate (Sabic SLX)
- 2) **SCREWS x 8** – to fasten Dome (Class 3 corrosion resistant).
- 3) **VENT/SOLID TABS** – ASA Polymer (Luran S 778 T).
- 4) **BREATHER FRAME** – ASA Polymer (Luran S 778 T).
- 5) **SEAL** – Construction Grade Polyurethane (Bostik Seal'N'Flex 1).
- 6) **SOAKER TRAY** – 0.55mm Corrosion Resistant Steel (Colorbond).
- 7) **UPPER RING** – Rigid98 (Miro Silver).
- 8) **ANGLE ADAPTOR: upto 45° or 90°** – Rigid98 (Miro Silver).
- 9) **RIGID LENGTHS: 625mm or 1250mm** – Rigid98 (Miro Silver).
- 10) **LOWER RING** – Rigid98 (Miro Silver).
- 11) **LOCKING RING** – White ABS Thermoplastic (BASF GP22).
- 12) **CEILING FRAME** – White ABS Thermoplastic (BASF GP22).
- 13) **DIFFUSERS x 2** – 3mm PMMA (Acrylic) with Seadrift texture.
- 14) **DIFFUSER HOLDER** – White ABS Thermoplastic (BASF GP22).
- 15) **SCREWS** – to retain Flexi-tube Locking Ring to Ceiling Frame.
- 16) **SCREWS** – to fasten Ceiling Frame, includes lock lug and cover cap.
- 17) **MAGNET** – N45 Grade / Rare Earth (Neodymium Iron Boron).
- 18) **FOAM SEAL** – 3mm x 6mm Foam.
- 19) **REFLECTIVE RING** – 0.45mm 430BA Stainless Steel.
- 20) **TAPE** – PVC Duct Tape (TESA 4050).
- 21) **FLEXI-TUBE** – Composite 3 layers including metalized polyester, aluminium foil and spring wire.

Sky Tunnel™ with Flexi-Tube

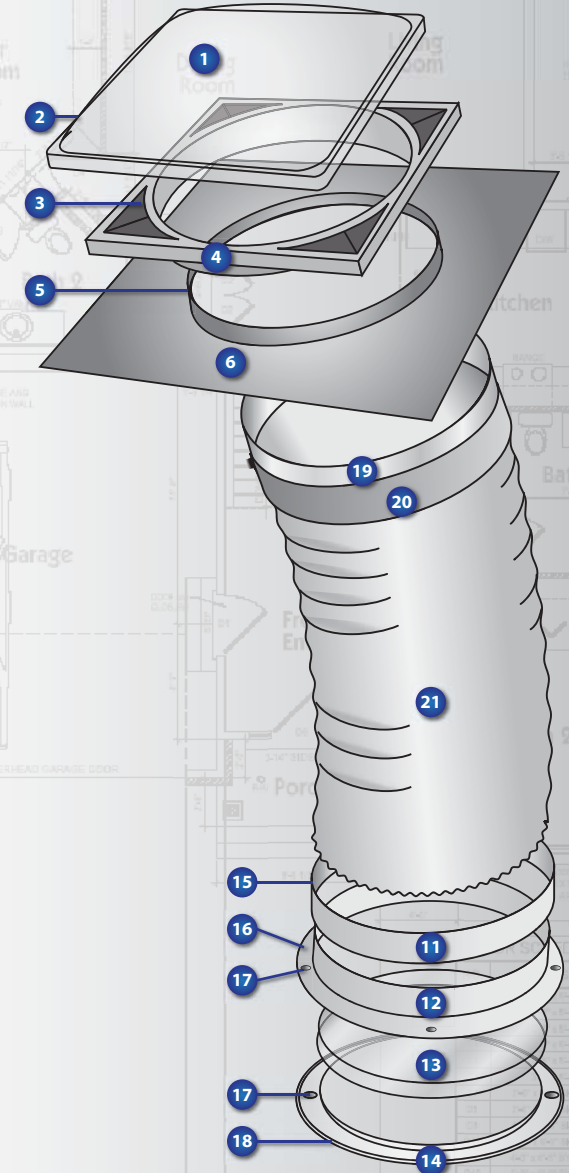

Sky Tunnel XL²

THREE SIZES AVAILABLE

Diameter = Actual Daylight Area

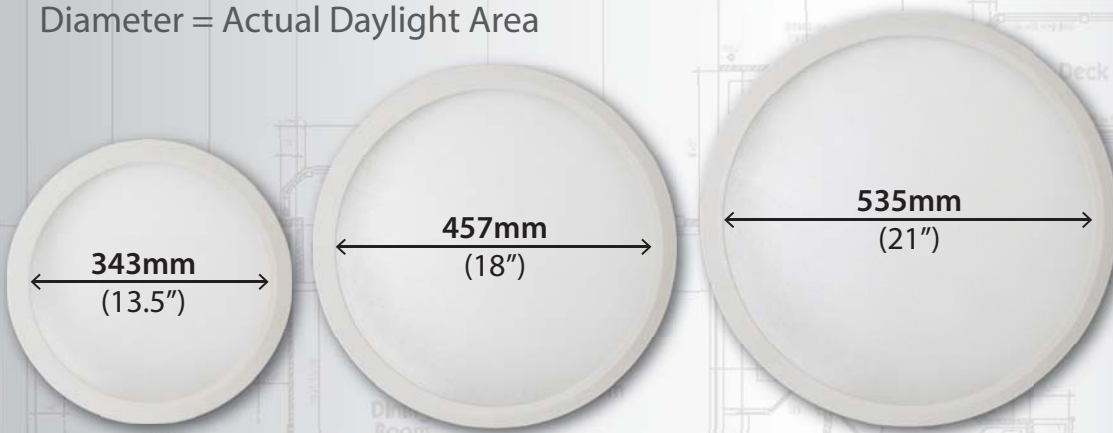

SPECIFYING THE SKY TUNNEL™

- ✎ The specified Daylighting System shall be the **Sky Tunnel XL²** manufactured by SG Eco Industries Inc.
- ✎ The Sky Tunnel shall have a daylight opening of _____ mm
(343mm, 457mm or 535mm)
- ✎ The Sky Tunnel dome shall be _____
(Acrylic or Polycarbonate)
- ✎ The Sky Tunnel tubing shall be _____
(Flexi-tube or Rigid98 Tube)
- ✎ The Sky Tunnel tubing shall be a length of _____ mm
- ✎ The Sky Tunnel shall be to suit a _____ roof
(Tile, CGI, Dek, etc.)

HOW MANY SKY TUNNEL™ DO I NEED?

For large open plan areas such as warehouses, factories and gymnasiums we recommend a spacing of between 5 - 6 metres, each unit will effectively light an area of between 25 - 36m².

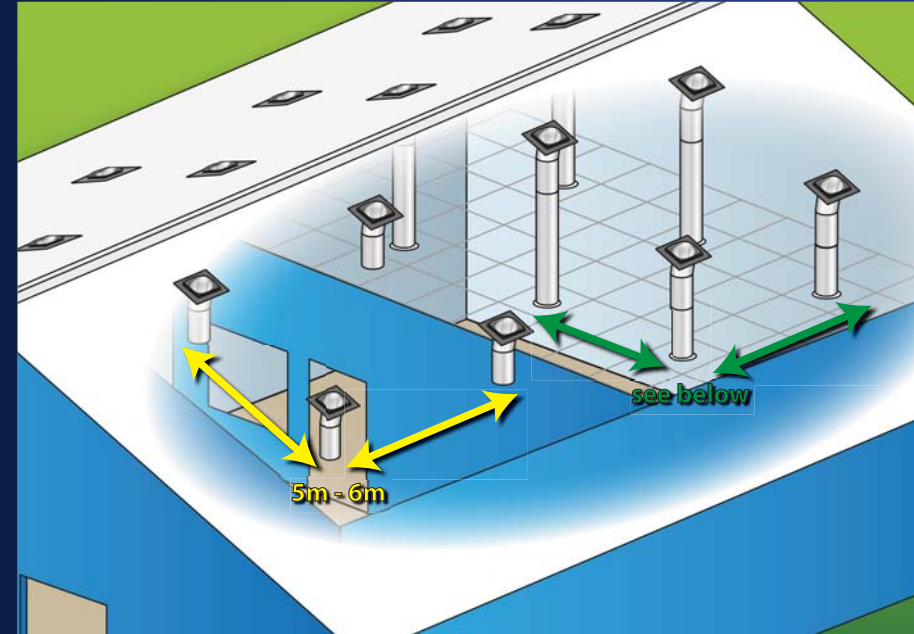

For applications including a ceiling we recommend the following spacings:

- 343mm dia Sky Tunnel™ with Rigid98 Tube: 4m x 4m (16m²)
- 457mm dia Sky Tunnel™ with Rigid98 Tube: 5m x 5m (25m²)
- 535mm dia Sky Tunnel™ with Rigid98 Tube: 6m x 6m (36m²)
- 343mm dia Sky Tunnel™ with Flexi-tube™: 3m x 3m (9m²)
- 457mm dia Sky Tunnel™ with Flexi-tube™: 4m x 4m (16m²)
- 535mm dia Sky Tunnel™ with Flexi-tube™: 5m x 5m (25m²)

Please note: Rigid98 Tube will give a superior luminance over a larger area.
For more information see the Attic Parts page.

SkyTunnel XL² ROOF PARTS

Includes the Dome, Breather Frame, Tabs, Soaker Tray and Flashing all assembled and ready to install.



Available to suit any roof type - Custom Flashings available



Custom Orb (CGI)



Dek



Hob (Curb) Mount



Flat (Shingle)



Tile



Slate

Which Dome type should I choose?

Sky Tunnel™ is available with either an Acrylic or Polycarbonate Dome. The Acrylic material is Altuglas HFI7 and suitable for almost all applications and is standard material used in Sky Tunnel™ Kits.

This Acrylic is impact modified, UV stabilized, Grade 1 virgin material with a visible light transmittance of 93%. This material has been used in the Sky Tunnel™ product for over 20 years.

In applications where higher impact resistance is critical, the Polycarbonate Dome should be used. This polycarbonate material is SABIC SLX and has exceptional impact resistance, is UV Stabilized and has a visible light transmittance of 87%.

SkyTunnel XL² ATTIC PARTS

Rigid98 Tube

SKY TUNNEL's Rigid98 Tubing is fabricated from Miro-Silver, a premium quality aluminium product manufactured by ALANOD in Germany. MIRO - SILVER® the next generation, has a total reflectivity of 98%. Normal anodised aluminum lighting grades have total reflectivity of up to 87%. To increase or enhance this total reflectivity to a higher level, several nanometer-thin optical coatings must be applied to the aluminum surface in a vacuum.

MIRO-SILVER delivers high efficiency luminance with little light transmission loss and the light stays completely white with no colour spectrum shift - even after numerous reflections. It is also extremely durable and will not fade or lose reflectivity.



MIRO-SILVER® Layer System

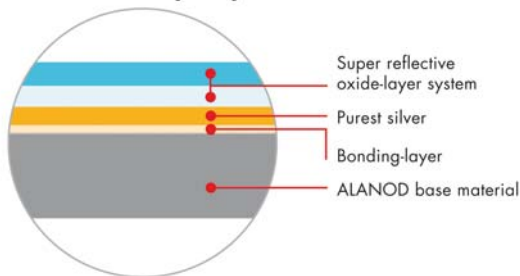

Flexi-Tube™

Flexi-tube™ is a tubing system that can be used in certain applications up to 3m in length. With up to 86% reflectivity, Flexi-tube™ is a cost effective alternative to Rigid98 Tube providing adequate light when applied in suitable applications. Installation of a Sky Tunnel™ with Flexi-tube™ is very easy as the flexibility allows the installation of the Roof Parts and Ceiling Parts to be off centre, so avoiding obstructions in the attic space is simple. Manufactured in house, from the highest quality local and imported materials, you can be sure our Flexi-tube™ will stand the test of time. After all, it already has for 20 years!



Flexi-tube™ Layers

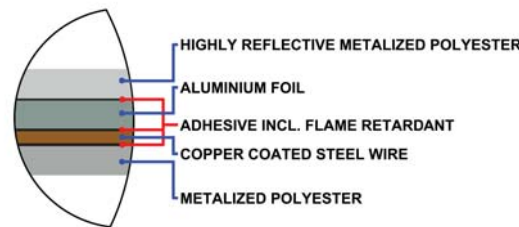

Which Tubing Option should I choose?

Rigid98 Tubing is recommended for almost all commercial applications. The superior performance of this tubing ensures you get the maximum performance where you need it.

Rigid98 Tubing is used in all commercial applications with no ceilings such as warehouses, factories, gymnasiums etc

Flexi-tube™ is predominantly used in residential applications. In commercial applications the use of Flexi-tube is in areas where higher luminance levels are not required such as toilets, change rooms, locker rooms etc.

Sky Tunnel XL² CEILING PARTS

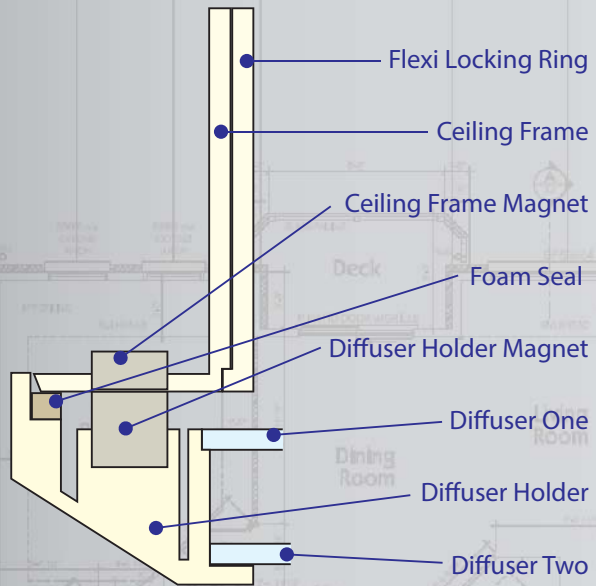

With Sky Tunnel™ a double glazed diffuser is a standard feature, not an optional extra. This provides a more energy efficient daylighting unit in all climates.

This double glazed diffuser is held in place by magnets sticking to other magnets in the surface of the ceiling frame. The double glazed diffuser also includes a foam seal, already installed for maximum energy efficiency.



CONVERSION BOX

Convert a 343mm, 457mm or 535mm diameter Sky Tunnel™ into a Diffuser System specifically designed for a standard 600mm x 600mm (2' x 2') Grid Ceiling System.

Available with either a single or double glazed diffuser. The aesthetic design allows the system to blend in with the Grid Ceiling System.

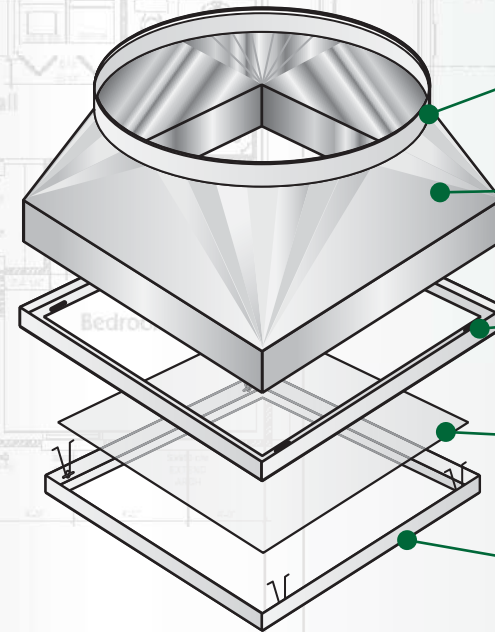

Connect your Rigid98 Tube or Flexi-tube to the Upper Trim of the Box.

The Conversion Box is made from Rigid98 Tube to ensure maximum light transmission.

The White Powdercoated Frame is attached to the uprights in the Ceiling Grid

Single or Double Glazed 3mm PMMA Diffusers are held into the Diffuser Holder.

The White Powdercoated Diffuser Holder is connected to the Frame with a unique spring system.



Sky Tunnel XL² Multiple Accessory Remote Control System (MARCS)



One Remote Control to operate the following accessories:

1. Vari-light

A single flap damper system allowing full control of the amount of daylight entering the room. 3 buttons on the remote - OPEN, CLOSE & STOP give you the option of setting the exact amount of daylight you want.

2. Power Kit - Exhaust Fan

Designed for use in bathrooms, toilets etc. allowing for the extraction of air from the room through the Sky Tunnel system. Two buttons on the remote for the fan - ON & OFF.

3. Electric Light

LED lighting system that can be installed inside the Sky Tunnel for night time use. Two buttons on the remote for the light - ON & OFF.

The system uses a "Learning" type remote allowing single or multiple units to be controlled by the one handheld remote control - the choice is yours.

The Receiver Input is 12V with a maximum load of 70W. The Exhaust Fan draws 18W, the Vari-light draws 2W and LED Lighting System approx 30W. Transformer Input 110V-240V, 50/60hz.

Sky Tunnel XL² ACCESSORIES

Vari-light

The Vari-light for the Sky Tunnel XL² allows you to control the amount of daylight entering the room, all by remote control. The Vari-light runs on 12V DC Electricity, and with a 2W motor uses almost no power to operate.

The remote control has 3 buttons - Open, Close & Stop. Press the open or close button once to start the Vari-light, and when you get to the desired level of daylight - press Stop. When the unit is closed the unit will still allow a minimal amount of light to enter the room.

The Vari-light can be controlled by the MARCS remote system.

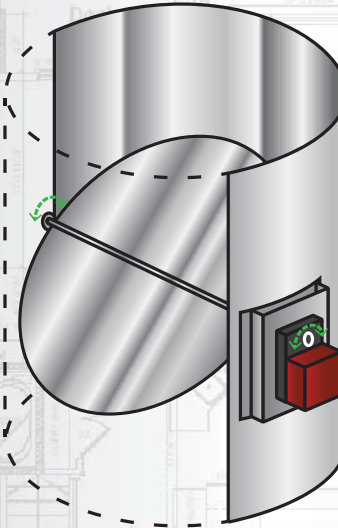

LED Light

The LED Light System for the Sky Tunnel XL² sits inside the tubing, just above the diffusers.

A different LED Light has been designed for each diameter Sky Tunnel™ to eliminate shadows during daylight hours and still give adequate luminance during night time hours.

The LED Light runs on 12V DC Electricity and can be controlled by the MARCS remote system.



Sky Tunnel XL² ACCESSORIES

Power Kit - Exhaust Fan

The Power Kit - Exhaust Fan for the Sky Tunnel XL² is a ventilation system ideal for small bathrooms, toilets or anywhere you need to exhaust air from a room which also requires daylighting. The Vari-light runs on 12V DC Electricity, and with a 18W motor uses approx Php0.22 (less than USD0.01) per hour.

The Exhaust Fan is located in the stainless steel take off unit just above the ceiling. The exhausted air is pushed up through a 150mm diameter flexible tube and out through a cowl on the roof parts of the Sky Tunnel™. The design of this system means you only have one roof penetration and one ceiling fixture that provide your ventilation & daylighting solution.

The Power Kit can be controlled by the MARCS remote system.

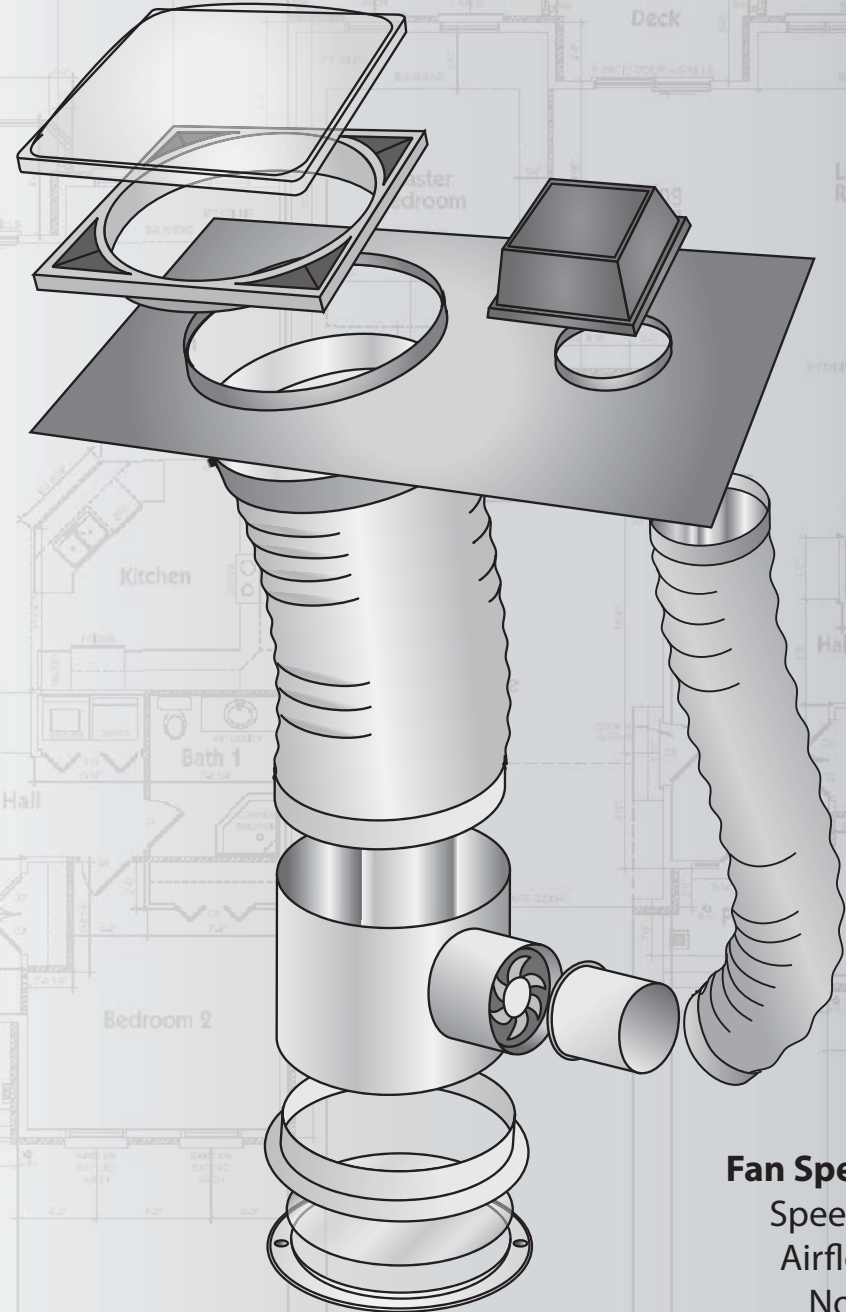

One ceiling fixture for Daylighting, Ventilation & Electric Lights.

Fan Specifications











Speed: 3000rpm

Airflow: 206cfm

Noise: 56.0dB



10 REASONS WHY YOU NEED SKYTUNNEL™

-  No Lighting Brownouts
-  No Running Costs
-  No Heat Load on Building
-  100% Color Rendition
-  Very Low Maintenance
-  Fast Return on Investment
-  Improves Occupants Comfort
-  Manufacturers Warranty
-  Environmentally Friendly
-  Improves Human Productivity

START SAVING ELECTRICITY NOW!

An average 400 Watt Hi Bay Electric Light costs up to Php12,500 (USD300) per year in electricity alone. Add maintenance & repairs and you have an expensive method of lighting your building. Electric lights also run at extreme temperatures, up to 90°C, increasing the overall heat load on the building. This will put extra pressure on Air-conditioning systems, in turn increasing





FREQUENTLY ASKED QUESTIONS

1. How much extra light will a Sky Tunnel™ give me?

There is no standard answer because of the variables that affect the performance of any skylight. Like time of year, time of day, throat size, length of shaft, dome orientation on the roof, room size, wall colours and general decor. Plus general weather & ambient light conditions always effect the end result.

Our many years of experience has taught us that an assessment of these variables, and your needs, is the most effective way that we can ensure that you get the natural light you're looking for. Your local Sky Tunnel dealer will be able to help you.

2. Does heat come through a Sky Tunnel™?

Minimal heat will enter through the Sky Tunnel™, as the unit is double glazed at ceiling level. It also has the dome at roof level, reducing heat transmittance, and none of the tubing components hold heat. Therefore there will be no additional heat load on the building. In fact compared to electrical lighting, or traditional skylights, the temperatures are significantly lower.

3. Will my Sky Tunnel™ leak?

No. The Sky Tunnel™ is watertight and guaranteed against leaking. Your installer or dealer will guarantee the the installation against any leaking. As part of the testing for Australian Standard AS4285, the Sky Tunnel™ was subjected to winds of 16 metres per second and water spray of 3 litres per second. Any water penetration is a failure. Sky Tunnel™ passed this and all other tests in AS4285.

4. What Warranty will my Sky Tunnel™ have?

The Sky Tunnel™ includes a 7 year manufacturers warranty.

5. Where is the Technology from? And where is the Sky Tunnel™ made?

The Sky Tunnel™ was invented in Australia in 1991, and sold under the name Sola Skylights. It was sold throughout the USA as Sun Tunnel, and the UK as Sky Tunnel™. Since 2007 the product has been sold worldwide as Sky Tunnel™.

Originally manufactured in Australia, the tooling and machinery was transferred to the Philippines in June 2008. All manufacturing now takes place in our factory in the Clark Freeport Zone, Pampanga.

6. How strong is the Dome?

The Acrylic Dome on the Sky Tunnel™ was live load tested to 120kg as per Australian Standard AS4285.

7. How important is the tubing material?

Very important as it transmits the outside light into your room. Key factors are the open area of the tubing, the length of the tubing, and that the tubing should be "shiny" and, in the case of a flexible tube, quite taunt. Our Rigid system uses Alanod Miro Silver with a total reflection of 98%. Using inferior products will dramatically reduce the efficiency of the Sky Tunnel™.

8. Does my interior colour scheme affect the performance of my Sky Tunnel™?

Yes it does. Light bright colours will tend to reflect daylight around the room while dark colours will tend to absorb daylight. Adjusting the size or quantity will help to solve this problem.

9. What is the maximum length of tubing?

For Flexi-tube we recommend a maximum of 3m, which covers over 95% of residential applications and some commercial applications. Any longer than this, we recommend using the Rigid98 Tubing system. This can be used effectively over 6m in length, however the longer the tubing, the less light transmittance. For more information look on the Attic Parts page of this brochure.

10. Can I turn off my Sky Tunnel™?

Yes. If you install the Vari-light, the Sky Tunnel™ can be opened & closed as required.

11. Can a Sky Tunnel™ be used on a multi-storey building?

Yes. As long as the space above the Sky Tunnel™ is clear so the tubing can run as straight as possible. Normally a void, such as a cupboard is placed above the Sky Tunnel so the tubing is not visible in the room it is running through.

The roof components should always be installed on a roof, placing them on a vertical wall is not recommended, as the light performance will not be adequate.

12. Can I have ventilation with my Sky Tunnel™?

Yes. The standard Sky Tunnel™ has the option of passive ventilation utilising our Interchangeable Vent System. For extra ventilation, you can install the Power Kit - Exhaust Fan.

13. Is security an issue with the Sky Tunnel™?

Our experience has shown us that the Sky Tunnel™ is not used as a method of entering a secure building. There is normally far easier and safer points of entry, with most crimes being opportunistic. For those who are concerned, we can advise several options which can be added to the Sky Tunnel™ to increase its security.

SkyTunnel XL² COMMERCIAL PROJECTS - PHILIPPINES

Nippon Express - Clark Freeport Zone, Pampanga.

Task: Eliminate the use of electric lighting in daylight hours.

Solution: 30 x 535mm Rigid98 Tube Warehouse Kits.

Philexcel Business Centre 2 - Clark Freeport Zone, Pampanga.

Task: Reduce energy consumption.

Solution: 28 x 343mm Rigid98 Tube Kits

Philexcel Main Office - Clark Freeport Zone, Pampanga.

Task: Reduce energy consumption.

Solution: 11 x 535mm Rigid98 Tube Kits, 16 x 457mm Rigid98 Tube Kits & 4 x 457mm Flexi-tube Kits

American Plaque Factory - Clark Freeport Zone, Pampanga.

Task: Improve the working environment for employees to increase productivity and improve quality control.

Solution: 28 x 535mm Rigid98 Tube Warehouse Kits, 25 x 535mm Rigid98 Tube Kits, 1 x 535mm & 3 x 457mm Flexi-tube Kits.

Toyota Motor Corp - Sta. Rosa City, Laguna.

Task: Reduce carbon footprint.

Solution: 65 x 535mm Rigid98 Tube Warehouse Kits.

Lucena Bus Terminal - Lucena City, Quezon.

Task: Improve visual aesthetics of the terminal.

Solution: 10 x 535mm Rigid98 Tube Kits.

JJ Supermarket - San Fernando, Pampanga.

Task: Reduce energy consumption and increase the visual aesthetics inside the supermarket.

Solution: 88 x 535mm Rigid98 Tube Warehouse Kits.

Green Cross - Parañaque City, Metro Manila.

Task: Reduce energy consumption without introducing any heat load on the building.

Solution: 15 x 535mm Rigid98 Tube Warehouse Kits & 26 x 535mm Rigid98 Tube Kits.

More information on the projects can be found on our website - www.eco.ph/case-studies



Philexcel Business Centre 2



Nippon Express



Philexcel Main Office



Amercian Plaque Factory



Green Cross



Toyota Motor Corp



Lucena Bus Terminal



JJ Supermarket

Sky Tunnel

Daylighting the world for more than 20 years!



SG Eco Industries Inc.

Building 15A Philexcel Business Park, M-Roxas Highway,
Clark Freeport Zone, Pampanga, PHILIPPINES

Ph: (045) 499 1037 **Fx:** (045) 499 1443

International: + 63 45 499 1037

Email: office@eco.ph **Web:** www.eco.ph

